

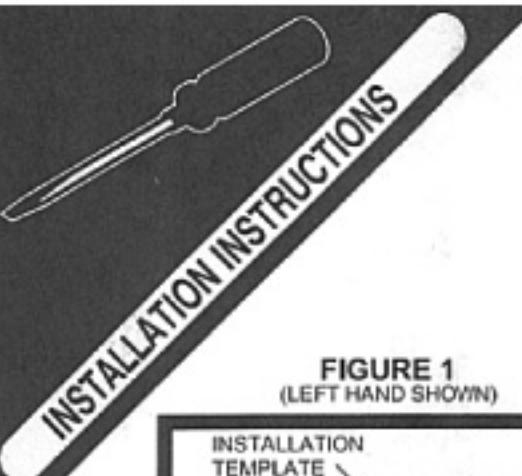

**Full Surface Reinforcing Pivot Hinge**  
**B-1921 & B-1923**

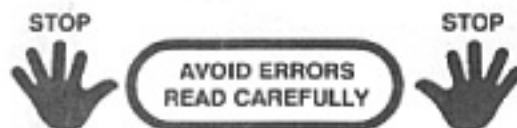

**FIGURE 1**  
(LEFT HAND SHOWN)

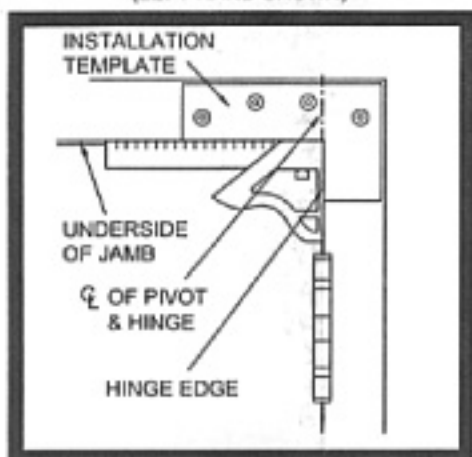

**FIGURE 2**  
(LEFT HAND SHOWN)

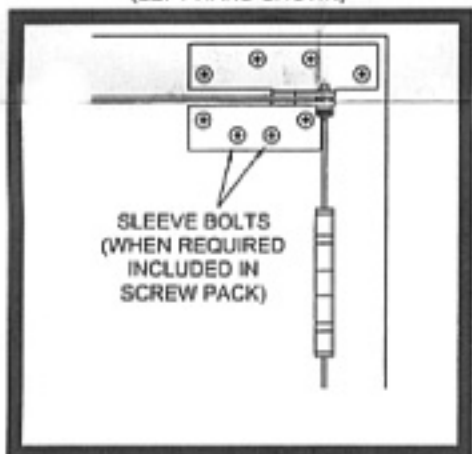

**FIGURE 3**

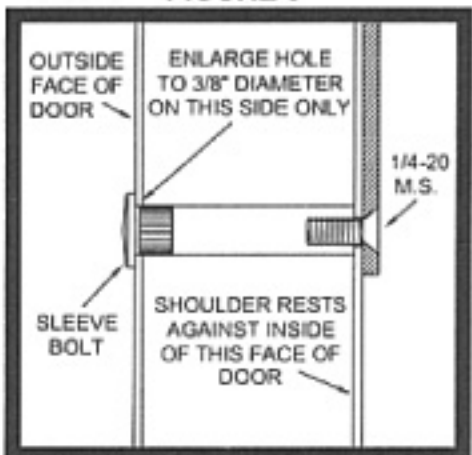

**STEP NO.1**

TO LOCATE PIVOT ON FRAME, HOLD COMBINATION SQUARE IN CORNER OF FRAME AND PLACE INSTALLATION TEMPLATE AGAINST SQUARE EXACTLY AS SHOWN. SPOT HOLE CENTERS WITH CENTER PUNCH.

**STEP NO.2**

DRILL HOLES REQUIRED AS PER SCHEDULE.

**METAL FRAME**

DRILL .2010 DIAMETER HOLES (NO.7 DRILL) FOR 1/4-20 MACHINE SCREW AND TAP HOLE.

*NOTE: IF MATERIAL THICKNESS IS NOT SUFFICIENT OR WHEN HOLLOW METAL FRAMES ARE NOT REINFORCED, USE #14 x 1 1/4" TYPE A SHEET METAL SCREWS.*

**WOOD FRAME**

DRILL PILOT HOLES AND INSTALL WOOD SCREWS

**STEP NO.3**

WITH DOOR IN PLACE, CHECK TO BE SURE THAT HINGES ARE FIRMLY ATTACHED AND THERE IS PROPER CLEARANCE BETWEEN DOOR AND FRAME AT ALL SIDES OF JAMB AND BOTTOM OF DOOR.

IF DOOR TENDS TO SAG AWAY FROM HINGE JAMB AT TOP, DRIVE WEDGES BETWEEN FRAME AND DOOR AT OPPOSITE STRIKE SIDE AND RE-ALIGN HINGES UNTIL DOOR IS PROPERLY POSITIONED TO SWING FREE.

**STEP NO.4**

PLACE DOOR PORTION OF PIVOT (WITH PIVOT IN PLACE) ON DOOR AND MOVE INTO POSITION SO THAT PIN ENTERS BRONZE BUSHING. WHEN PROPERLY ALIGNED WITH LOWER PART MAKING LIGHT CONTACT WITH BEARING FLANGE, HOLD FIRMLY IN PLACE, PARALLEL WITH HEAD OF DOOR AND MARK HOLE LOCATIONS.

**STEP NO.5**

REPEAT DRILLING INSTRUCTIONS NOTED IN STEP NO.2 FOR METAL DOORS, DRILL .2010 DIAMETER HOLES (NO.7 DRILL) FOR 1/4-20 MACHINE SCREWS AND TAP HOLE.

*NOTE: USE TWO SLEEVE BOLTS FURNISHED WITH EACH PIVOT. USE AS REQUIRED FOR HOLLOW METAL, OR MINERAL CORE DOORS. (SEE FIG.3) DRILL 1/4" HOLE THRU DOOR. ENLARGE HOLE ON SIDE OPPOSITE PIVOT TO 3/8" DIAMETER FOR SLEEVE BOLT.*